

# AI-519 ARTIFICIAL INTELLIGENCE INDUSTRIAL CONTROLLER

## Operation Instruction

Ver. 7.5

*(Applicable for accurate controls of temperature, pressure, flow, level, humidity etc.)*

### CONTENTS

<b>1. SUMMARY.....</b>	<b>1</b>
1.1 MAIN FEATURES .....	1
1.2 TECHNICAL SPECIFICATION.....	1
1.3 ORDERING CODE DEFINITION .....	2
1.4 REAR TERMINAL LAYOUT AND WIRING .....	5
<b>2. DISPLAYS AND OPERATIONS .....</b>	<b>6</b>
2.1 FRONT PANEL DESCRIPTION.....	6
2.2 PARAMETER SETTING FLOW CHART.....	7
2.3 OPERATION DESCRIPTION .....	7
2.3.1 Set Value Setting.....	7
2.3.2 Parameter Setting.....	7
2.3.3 Setpoint / Output Value Switch.....	8
2.3.4 Auto / Manula Control Mode Switch.....	8
2.3.5 Auto Tuning .....	8
<b>3. PARAMETERS AND SETTINGS .....</b>	<b>8</b>
3.1 PARAMETER LOCK (LOC) AND FIELD PARAMETERS .....	8
3.2 THE ENTIRE PARAMETER TABLE.....	9
3.3 ADDITIONAL REMARKS OF SPECIAL FUNCTIONS.....	12
3.3.1 Single-phase phase-shift trigger output.....	12
3.3.2 Alarm blocking at the beginning of power on .....	12
3.3.3 Setpoints switch .....	12
3.3.4 Communication function .....	12
3.3.5 Temperature retransmitter / set current output.....	12

## 1. SUMMARY

### 1.1 Main Features

- Universal thermocouples and selectable RTDs and linear current/voltage signals. Integrating non-linear graduation tables, digital calibration and auto zero technology to achieve accurate and stable measurement.
- Advanced artificial intelligence (AI) control algorithm with auto tuning function without overshooting.
- Auto/manual bumpless switch and soft-start function.
- New generation X3 and X5 current output modules with accuracy 0.2%F.S., improving the precision of control and retransmission.
- Advanced modular structure giving plenty of output options to satisfy all kinds of applications. Quick delivery and easy maintenance.
- User-friendly and customized operating interface for easy learning and simple manipulation. All parameters can be promoted to quick operator access in Field Parameter Table or kept in password protected Full Parameter Table.
- Worldwide power supply of 100-240VAC or 24VDC and various dimensions. Power frequency 50Hz or 60Hz and unit of °C/ °F are selectable in parameter.
- High quality hardware design, using high performance tantalum capacitor or ceramic capacitor. Compared to competing models, it consumes less electricity, experiences less temperature shifting, provides higher stability and reliability, and can work in a wider range of temperature.
- ISO9001 and CE certified, achieving world class level of quality, anti-interference ability and safety.

#### POINTS TO NOTE

- Always adjust parameters according to input / output type and function. Only correctly wired instruments with appropriate parameters shall be put into use.

### 1.2 Technical Specification

- **Input type: (Any of below specifications can be used selectively in the same instrument)**

Thermocouple: K, S, R, E, J, N

Resistance temperature detector: Cu50, Pt100

Linear voltage: 0~5V, 1~5V, 0~1V, 0~100mV, 0~20mV, etc.

Linear current (external precise shunt resist needed): 0~10mA, 0~20mA, 4~20mA, etc.

Extended input (install I4 module in MIO) : 0~20mA, 4~20mA or two line transmitter.

- **Instrument Input range**

K(0~1300°C), S(0~1700°C), R(0~1700°C), E(0~1000°C), J(0~1200°C), N(0~1300°C)

K(32~2372°F), S(32~3092°F), R(32~3092°F), E(32~1832°F), J(32~2192°F), N(32~2372°F)

Cu50(-50~+150°C), Pt100(-200~+800°C)

Cu50(-58~+302°F), Pt100(-328~+1472°F)

Linear Input: -9990~+30000 units defined by user.

- **Measurement accuracy** : 0.3%FS ± 0.1°C
- **Resolution** : 0.1°C for K, E, T, N, J, Cu50, Pt100; 1°C for S, R
- **Temperature shift** : ≤0.015%FS /°C (typical value is 70ppm/°C)
- **Sampling period** : read A/D converter 8 times per second
- **Response time** : ≤1s ( when digital filter parameter FILt=1)
- **Alarm function** : high limit, low limit, deviation high limit and deviation low limit; with alarm blocking at the beginning of power on.

- **Control mode:**  
On-off control mode (Hysteresis adjustable)  
Standard PID with auto tuning  
AI PID with auto tuning, adopting AI artificial intelligence algorithm.
- **Control period :** 0.5~120.0 seconds selectable, and it should be integer times of 0.5 second.
- **Output mode (modularized)**  
**Relay output (NO+NC):** 250VAC/2A or 30VDC/1A  
**TRIAC no contact discrete output (NO or NC):** 100~240VAC/0.2A (continuous), 2A (20mS instantaneous, repeat period ≥5s)  
**SSR Voltage output:** 12VDC/30mA (used to drive SSR).  
**Thyristor zero crossing trigger output:** can trigger TRIAC of 5~500A, a pair of inverse paralleled SCRs or SCR power module.  
**Linear current output:** 0~20mA, 4~20mA (Output voltage ≥11V, maximum load resistor 500ohm, output precision 0.2%FS)
- **Electromagnetic compatibility (EMC) :** ±4KV/5KHz according to IEC61000-4-4; 4KV according to IEC61000-4-5.
- **Isolation withstanding voltage :** between power, relay contact or signal terminal ≥2300VDC; between isolated electroweak terminals ≥600VDC
- **Power supply :** 100~240VAC, -15%, +10% / 50-60Hz; 120~240VDC; or 24VDC/AC, -15%, +10%.
- **Power consumption:** ≤6W
- **Operating Ambient :** temperature -10~60℃; humidity ≤90%RH
- **Front panel dimension:** 96×96mm, 160×80mm, 80×160mm, 48×96mm, 96×48mm, 48×48mm, 72×72mm
- **Panel cutout dimension:** 92×92mm, 152×76mm, 76×152mm, 45×92mm, 92×45mm, 45×45mm, 68×68mm
- **Depth behind mounting surface:** ≤100mm

### 1.3 Ordering Code Definition

AI series instruments adopt advanced modularized hardware design. There are maximum five module slots: multi-function input/output (MIO), main output (OUTP), alarm (ALM), auxiliary output (AUX) and communication (COMM). The modules can be purchased in bundle with instrument or separately, and can be installed easily. The input type can be freely set to thermocouple, RTD, or linear current/voltage.

The ordering code of AI-508 series instrument is made up of 8 parts. For example:

**AI-519   A   N   X3   L5   N   S4 — 24VDC**  
 ①        ②        ③        ④        ⑤        ⑥        ⑦        ⑧

It implies that the model is AI-519, front panel dimension is 96×96mm, no module installed in MIO (Multi-function I/O) slot, X3 linear current output module installed in OUTP (main output), L5 (dual relay contact output module) in ALM (alarm), no module installed in AUX (auxiliary output), RS485 communication interface with photoelectric isolation is installed. The power supply of the instrument is 24VDC.

Order code in details:

① **shows the model of the instrument**

**AI-519** economical type instrument with measurement accuracy 0.3%F.S. It adopts artificial intelligent control technology, with functions of auto/manual bumpless switch.

② **shows the front panel dimension.**

**A/A2** front panel 96×96mm(width×height), cut out 92×92mm, depth behind mounting surface 100mm. A2 has a light bar with 25 segments and 4 levels of luminosity.

**B** front panel 160×80mm(width×height), cut out 152×76mm, depth behind mounting surface 100mm.

**C/C3** front panel 80×160mm(width×height), cut out 76×152mm, depth behind mounting surface 100mm. C3

---

has an additional light bar with 50 segments and 2 levels of luminosity.

- D** front panel 72×72mm(width×height), cut out 68×68mm, depth behind mounting surface 95mm
- D2** front panel 48×48mm(width×height), cut out 45×45mm, depth behind mounting surface 95mm`
- E** front panel 48×96mm(width×height), cut out 45×92mm, depth behind mounting surface 100mm
- F** front panel 96×48mm(width×height), cut out 92×45mm, depth behind mounting surface 100mm

③ **shows the module type of multiple function I/O (MIO). N means none, no module installed.**

**V24/V12/V10** Isolated 24V/12V/10V DC voltage output module with maximum current of 50mA, can supply power for external transmitter.

**I2** On-off signal input module, can connect an external switch to switch between dual setpoints.

**I4** 4-20mA/0-20mA analogue input module, has a 24VDC/24mA power supply, and can connect to 2-wire transmitter.

④ **shows the module type of main output (OUTP). For control output or SV/PV retransmission.**

**L2** Normal open + normal close relay output module (small volume, capacity: 30VDC/1A, 250VAC/1A)

**L1/L4** Large capacity normal open relay output module (large volume, capacity: 30VDC/2A, 250VAC/2A)

**W1** TRIAC no contact normal open discrete output module (Capacity: 100-240VAC/0.2A, burnt free)

**W2** TRIAC no contact normal closed discrete output module (Capacity: 100-240VAC/0.2A, burnt free)

**G** SSR voltage output module (DC12VDC/30mA)

**K1** Single-phase thyristor zero crossing trigger output module (can trigger one loop of a TRIAC or a pair of inverse parallel SCR with current of 5-500A)

**K3** Three-phase thyristor zero crossing trigger output module (can trigger 3-phase circuit; each loop can trigger TRIAC or a pair of inverse parallel SCR with current of 5-500A)

**K5** Single-phase thyristor phase-shift trigger output module, suitable for 200~240VAC power.

**K6** Single-phase thyristor phase-shift trigger output module, suitable for 340~415VAC power.

**X3** Electric isolated linear current output module, support outputs of 0-20mA and 4-20mA etc, and use internal 12VDC power supply.

**X5** Electric isolated linear current output module, support outputs of 0-20mA and 4-20mA etc. X5 is equipped with photoelectric isolated power supply and doesn't interfere with the internal power of the instrument.

⑤ **shows the module type of alarm (ALM). For AL1 and AL2 alarm outputs.**

**L1/L2/L4** Single relay output alarm, support AL1.

**L5** Dual normal open relay output module, support AL1 and AL2.

⑥ **shows the module type of auxiliary output (AUX). For AU1 and AU2 alarms and control auxiliary output.**

**L1/L2/L4** Single relay output alarm, support AU1 alarm or auxiliary output of refrigerating/heating control.

**L5** Dual normal open relay output module, support AU1 and AU2 alarm.

**W1** TRIAC no contact normal open discrete output module (Capacity: 100-240VAC/0.2A, burn proof)

**W2** TRIAC no contact normal closed discrete output module (Capacity: 100-240VAC/0.2A, burn proof)

**G** SSR voltage output module (DC12V/30mA time proportional output)

**K1** Single-phase thyristor zero crossing trigger output module (can trigger one loop of a TRIAC or a pair of inverse parallel SCR with current of 5-500A)

**X3** Electric isolated linear current output module, support outputs of 0-20mA and 4-20mA etc, and use internal 12VDC power supply.

**X5** Electric isolated linear current output module, support outputs of 0-20mA and 4-20mA etc. X5 is equipped with photoelectric isolated power supply and doesn't interfere with the internal power of the instrument.

**R** RS232 communication interface module, use the internal 12VDC power supply.

⑦ **shows the module type of communication (COMM).**

**S** RS485 communication interface module, use the internal 12VDC power supply.

**S4** RS485 communication interface module. S4 is equipped with photoelectric isolated power supply, and doesn't

---

interfere with the internal power supply of the instrument.

- ⑧ **shows the power supply of the instrument.** If left blank, the power of the instrument is 100-240VAC. "24VDC" means the power supply of 24V direct current.

**Module K3:** K3 module will take OUP and MIO two slots. So if K3 is installed, installing I2 module in COMM slot and setting parameter bAud to 1 can realize two setpoints switching function.

**Installation and replacement of modules:** Before the instrument delivery, module installation is done on request, with corresponding parameter set correctly. Users can replace or install modules by themselves when needed. When replacing a module, you should pull the controller out of the housing at first, insert a small flat-tip screwdriver into the opening between the original module and the slot on motherboard to remove the old module, and then install a new module. Changing module type needs to modify the corresponding parameters.

**Voltage output module:** The voltage output modules like V24, V10 or V12 are often used for supplying power for external transducer or feedback resistance of transmitter. These modules can be installed in any slot except that of D2 dimension instrument. To standardize the wiring, it is recommended to be installed in the first idle slot in the order of MIO, AUX, and COMM.

**Electric isolation of the modules:** There are a group of 24V and a group 12V power supply built in the instrument and isolated to the main circuit. The 24V power commonly supplies voltage output module, such as V24/V12/V10 (24V/12V/10V voltage output module), I2 (on-off signal input module) and I4 (linear current input module). The 12V power is commonly supplies output or communication module. Generally, the relay contact output and TRIAC no contact discrete output are self insulated from the other circuit, no matter whether other modules are installed or not. SSR voltage output do not need to be insulated from input circuit, because SSR itself has isolation function. Therefore, only the electric isolation between the communication interface and the current output should be considered. Those modules, for example, S (RS485 communication interface), R (RS232 communication interface) and X3 (linear current output), all need the 12V power supply. If more than one of the above modules are installed, in order to be electric isolated, only one of them can be module without electric isolation, the other modules should be S4 or X4, which has its own isolated power supply. For example, if an X module is installed in OUP (main output) slot, and an S or X module is installed in COMM (communication interface) slot, then OUP and COMM can not be electric isolated, so S or X should be replaced with S4 or X4.

**No contact switch module:** W1 and W2 are new types of no contact switch modules which apply the advanced technology of "burn proof" and zero crossing conduction. It can replace the relay contact switch. Compared to the relay contact output module, W1 and W2 have longer life and lower interference. They can largely decrease the interference spark of the equipment, and greatly improve the stability and reliability of the system. Since the driver element is TRIAC, it is suitable for controlling 100-240VAC (not for DC power) with current up to 80A. For the current larger than 80A, an intermediate relay is needed. Protection elements are series wound to the output terminals, so it can control continuous current up to 0.2A with maximum allowed instantaneous current 2A.

**Relay Module:** The relay modules are widely used in industrial control. However, they are the only modules with life time limit and volume limit and have much electromagnetic interference. There are four types of relay modules: L1, L2, L4 and L5. For control output, L1 or L4 large capacity module is recommended. L4 is equipped with high performance relay with small volume and large capacity but is expensive. L2 module is small, and both its normal open and normal close terminals have the function of varistor spark absorption, but the capacity is small. It is suitable for alarm output. L1 and L5 have big volume and big capacity. In the 48mm dimension instrument (for example, D2, E, F and E5), only one of L1 or L5 can be installed. L5 has dual output, can be used to support two loops of alarm, for example, AL1+AL2. If you don't like mechanical switch, you can choose G5 (dual SSR voltage driver) and connect with external SSR instead.

**Calibration:** The instrument applies the technology of automatic zero and digital calibration, and is free of maintenance. If the error exceeds certain range, generally, cleaning and drying the inside of the instrument can fix it. If not, send the instrument back to the factory to examine and repair.

**Warranty and maintenance:** Free repair and maintenance will be given in 36 months since the delivery. In order to get full and correct repair, write the phenomena and causes of the malfunction of the instrument.

## 1.4 Rear Terminal Layout and Wiring

**Wiring graph for instruments except D and D2 dimension.**

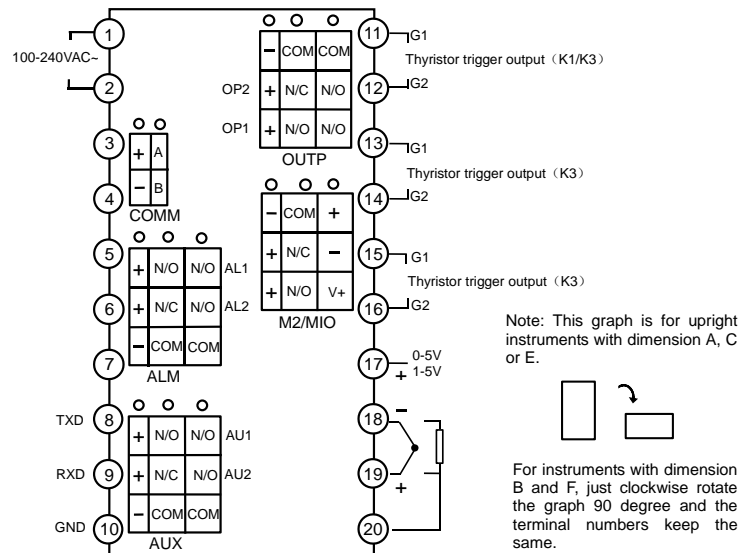

Note 1: For linear voltage input, if the range is below 500mV, connect to terminals 19 and 18. 0~5V or 1~5V signal can be inputted from terminals 17 and 18.

Note 2: 4~20mA signal can be converted to 1~5V signal by a 250 ohm resistor and inputted from terminals 17 and 18. If I4 module is installed in MIO slot, 4~20mA signal can be inputted from terminals 14+ and 15-, and 2-wire transmitter can be inputted from terminals 16+ and 14-.

Note 3: The compensation wires for different kinds of thermocouple are different, and should be directly connect to the terminals. When the internal auto compensation mode is used, connecting the common wire between the compensation wire and the terminals will cause measurement error.

### Wiring graph of D dimension instruments (72x72mm)

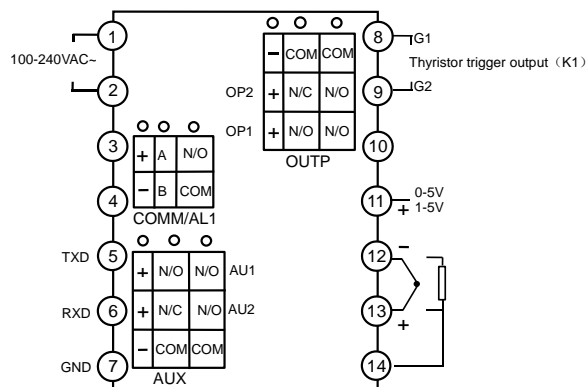

Note 1: Linear voltage signal of range below 500mV should be inputted from terminals 13 and 12, and signal of 0~5V and 1~5V should be inputted from terminals 11 and 12.

Note 2: 4~20mA linear current signal can be converted to 1~5V voltage signal by connecting a 250 ohm resistor and inputted from terminals 11 and 12.

Note 3: S or S4 module can be installed in COMM slot for communication. If relay, TRIAC no contact switch, or SSR driver voltage output module is installed in COMM, it can be used as alarm output. If I2 module is installed in COMM and parameter “bAud” is set to 1, then on-off signal can be inputted, and setpoints SV1 and SV2 can be switched by connecting a switch between terminals 3 and 4.

**Wiring graph of instruments with D2 dimension as below:**

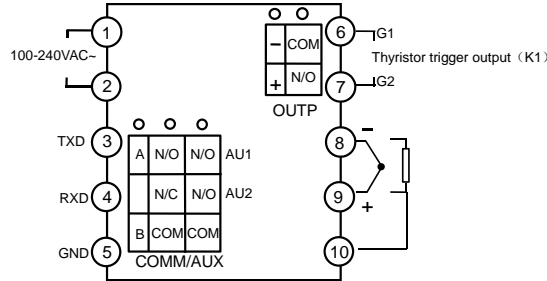

Note 1: D2 dimension instruments don't support 0~5V or 1~5V linear voltage input. However, 0~5V or 1~5V signal can be converted to 0~500mV or 100~500mV by connecting external precise resistors, 4~20mA can be converted to 100~500mV by connecting a 25ohm resistor, then be inputted from terminals 9 and 8.

Note 2: For COMM/AUX slot, if S or S4 communication module is installed, it can be used for communication; if L2 or L5 module is installed in, and parameter bAud is set to 0, it can be used for AU1 or AU1+AU2 alarm output; if L1, L2, L4, G, K1, W1 or W2 is installed, it can be the auxiliary output in bidirectional (heating/refrigerating) control (Auxiliary output doesn't support analog current output); if I2 is installed and bAud is set to 1, then it can input on-off signal to switch SV1 and SV2 by connecting a switch between terminals number 3 and 5.

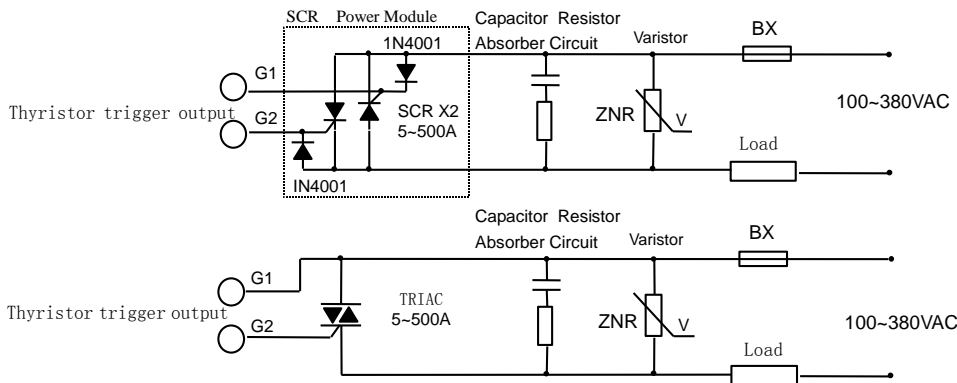

Note 1: According to the voltage and current of load, choose suitable varistor to prevent the thyristor. Capacitor resistor absorber is needed for inductance load or phase-shift trigger output.

Note 2: SCR power module is recommended. A power module includes two SCRs, is similar to the above dashed square.

Note 3: K5 phase-shift trigger module only support 200~240VAC / 50Hz power, and K6 phase-shift trigger module only support 340~415VAC / 50Hz power.

## 2. DISPLAYS AND OPERATIONS

### 2.1 Front Panel Description

- ① Upper display window, displays PV, parameter code, etc.
- ② Lower display window, displays SV, parameter value, or alarm code.
- ③ Setup key, for accessing parameter table and conforming parameter modification.

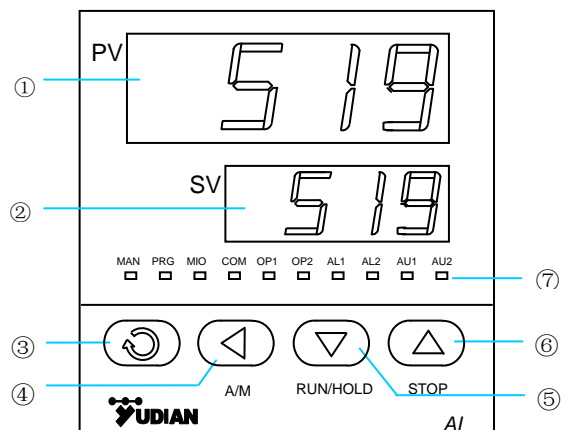

- ④ Data shift key, and also for auto tuning, auto/manual switch.
- ⑤ Data decrease key, and also run/pause switch
- ⑥ Data increase key, and also stop key
- ⑦ LED indicator. PRG indicator is non-applicable for AI-519. The lighting of MAN means in manual output status. MIO, OP1, OP2, AL1, AL2, AU1 and AU2 indicate I/O operation of the corresponding module. For example, That the COMM indicator is lighting means that the instrument is communicating with computer.

**Basic display status :** When power on, the upper display window of the instrument shows the process value (PV), and the lower window shows the setpoint (SV). This status is called basic display status. When the input signal is out of the measurable range (for example, the thermocouple or RTD circuit is break, or input specification sets wrong), the upper

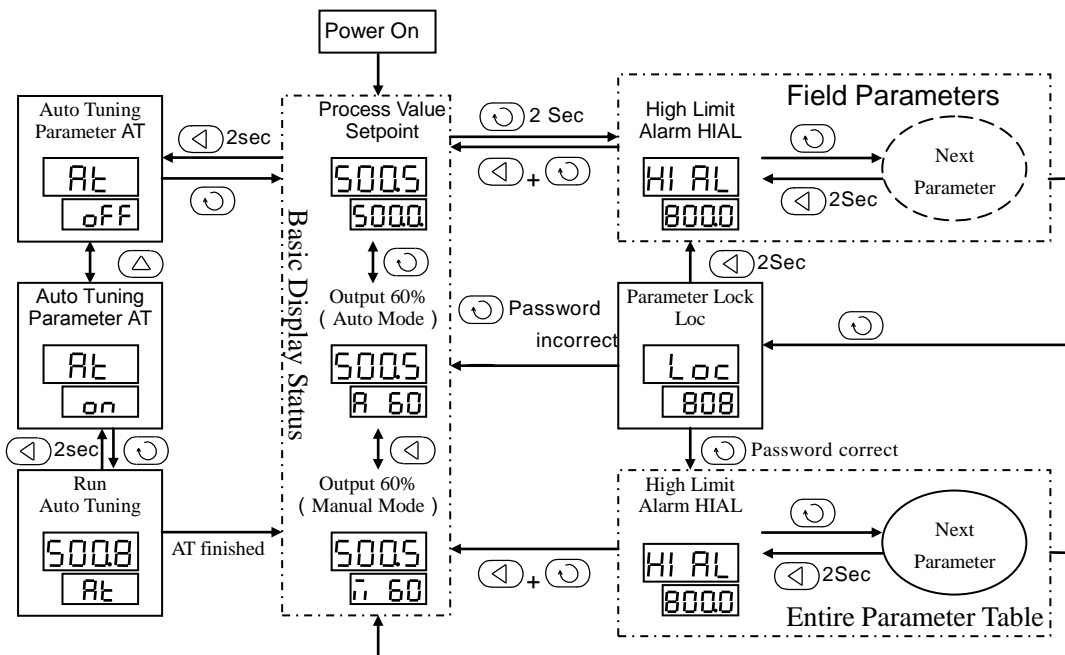

display window will alternately display “orAL” and the high limit or the low limit of PV, and the instrument will automatically stop output. If the lower display window alternately display “HIAL”, “LoAL”, “HdAL” or “LdAL”, it means high limit alarm, low limit alarm, deviation high alarm, and deviation low alarm happening. The alarm display can also be turned off by setting parameter AdIS to oFF. If “EErr” is displayed, it means internal self-test error, and the instrument should be sent back for repair

## 2.2 Parameter Setting Flow Char

### 2.3 Operation Description

#### 2.3.1 Set Value Setting

In basic display status, if the parameter lock “Loc” isn't locked, we can set setpoint (SV) by pressing  $\leftarrow$ ,  $\checkmark$  or  $\rightarrow$ . Press  $\checkmark$  key to decrease the value,  $\rightarrow$  key to increase the value, and  $\leftarrow$  key to move to the digit expected to modify. Keep pressing  $\checkmark$  or  $\rightarrow$ , the speed of decreasing or inscreasing value gets quick. The range of setpoint is between the parameter SPL and SPH.

#### 2.3.2 Parameter Setting

In basic display status, press  $\square$  and hold for about 2 seconds can access Field Parameter Table. Pressing  $\square$  can go to the next parameter; pressing  $\leftarrow$ ,  $\checkmark$  or  $\rightarrow$  can modify a parameter. Press and hold  $\leftarrow$  can return to the preceding parameter. Press  $\leftarrow$  (don't release) and then press  $\square$  key simultaneously can escape from the parameter table. The instrument will escape auomatically from the parameter table if no key is pressed within 25 seconds, and the change of the last parameter will not be saved.

In Field Parameter Table, press  $\square$  till the last field parameter Loc appears. Setting Loc=password and then press  $\square$  can access System Parameter Table.





---





### 2.3.3 Setpoint / Output Value Switch

In the basic display status, pressing  can switch lower display window between displaying setpoint and displaying output value. If the instrument is in manual operating mode, when the lower display window is switched to setpoint display, it will auto return to output value display after a period of time.

### 2.3.4 Auto / Manual Control Mode Switch

When output value is displayed in lower display window, pressing A/M () key can switch between auto control and manual control. If the instrument is in manual control mode and the lower display window is displaying output value, the output value can be modified by pressing  or . By setting A-M parameter, the instrument can be fixed at auto or manual control mode, and avoid mistaken switch.

### 2.3.5 Auto Tuning

When artificial intelligence PID control or standard PID control is chosen (Ctrl=APId or nPid), the PID parameters can be obtained by running auto-tuning. In basic display status, press  for 2 seconds, the "At" parameter will appear. Press  to change the value of "At" from "oFF" to "on", then press  to active the auto-tuning process. During auto tuning, "At" will flash at lower display window and the instrument executes on-off control. After 2 cycles of on-off action, the instrument will obtain the values of PID control parameters. If you want to escape from auto tuning status, press and hold  for about 2 seconds until the "At" parameter appears again. Change "At" from "on" to "oFF", press  to confirm, then the auto tuning process will be cancelled. After satisfying PID parameters are obtained, At is recommended to be "FoFF" which prevents activating auto tuning in basic display status.

**Note 1:** AI-519 instruments apply the advanced artificial intelligence algorithm, which has avoided the overshoot problem of standard PID algorithm, and achieve precise control.

**Note 2:** If the setpoint is different, the parameters obtained from auto-tuning are possibly different. So you'd better set setpoint to an often-used value or middle value first, and then start auto-tuning. For the ovens with good heat preservation, the setpoint can be set to the highest applicable temperature. It is forbidden to change SV during auto tuning. Depending on the system, the auto-tuning time can be from several seconds to several hours.

**Note 3:** Parameter CHYS (on-off differential, control hysteresis) has influence on the accuracy of auto-tuning. Generally, the smaller the value of CHYS, the higher is the precision of auto tuning. But the value of CHYS parameter should be large enough to prevent the instrument from error action around setpoint due to the oscillation of input. CHYS is recommended to be 2.0.

**Note 4:** In a heating/refrigerating dual output system, auto tuning should be executed at the main output (OUTP).

**Note 5:** AI series instrument has the function of self-adaptation. It is able to learn the process while working. The control effect at the first run after auto tuning is probably not perfect, but excellent control result will be obtained after a period of time because of self-adaptation.

## 3. PARAMETERS AND SETTINGS

### 3.1 Parameter Lock (Loc) and Field Parameters

In order to protect important parameters from being modified by mistake, but also offer enough flexibility for field control, parameter lock (Loc) and field parameters are introduced.

The parameters need to be displayed and modified in the work field are called Field Parameters. The set of field parameters is a subset of the whole parameter set, and can be freely chosen by user.

Loc can authorize different security right as below:

Loc=0~1, allowed to modify field parameters and setpoint, and execute auto tuning;

Loc=2, allowed to modify field parameters, but can't modify setpoint.

Loc=3~255: can only modify "Loc"

Setting Loc=PASd (Password, a number between 256 and 9999. Default is 808) and then pressing , can enter the whole parameter table and modify all parameters.

1 to 8 field parameters can be defined by parameters EP1 to EP8. If the number of the field parameters is less than 8,

the first idle EP parameter should be set to "nonE".

<b>Parameters</b>	EP1	EP2	EP3	EP4	EP5	EP6	EP7	EP8	Loc
<b>Default Value</b>	HIAL	LoAL	HdAL	LdAL	nonE	nonE	nonE	nonE	0

You can redefine field parameters and Loc to change operation style. For example, you can execute auto tuning from field parameter instead of by pressing  $\leftarrow$  in basic display status, and only take HIAL and HdAL as field parameter.

<b>Parameters</b>	EP1	EP2	EP3	EP4	EP5	EP6	EP7	EP8	Loc	At
<b>Default Value</b>	HIAL	HdAL	At	nonE	nonE	nonE	nonE	nonE	0	FoFF

### 3.2 The Entire Parameter Table

The parameters can be divided to 8 groups including alarm, control, input, output, communication, system, setpoint and field parameter definition. They are listed as below in sequence:

Code	Name	Description	Setting Range
<b>HIAL</b>	High limit alarm	Alarm on when PV (Process Value) >HIAL; alarm off when PV<HIAL-AHYS Alarm output action can be defined by parameter AOP.	-9990~ +30000 units
<b>LoAL</b>	Low limit alarm	Alarm on when PV<LoAL; alarm off when PV>LoAL+AHYS	
<b>HdAL</b>	Deviation high alarm	Alarm on when PV-SV>HdAL; alarm off when PV-SV<HdAL-AHYS	
<b>LdAL</b>	Deviation low alarm	Alarm on when PV-SV<LdAL; alarm off when PV-SV>LdAL+AHYS HdAL and LdAL can also be used as high limit and low limit alarms when needed. (Refer to the description of parameter AF)	
<b>AHYS</b>	Alarm hysteresis	Avoid frequent alarm on-off action because of the fluctuation of PV	0~2000 units
<b>AdIS</b>	Alarm display	oFF : don't display AdIS in the lower display window when alarming; on : alternately display AdIS in the lower display window when alarming.	oFF on
<b>AOP</b>	Alarm output allocation	From right side to left side, the first, second, third and fourth digit of AOP individually indicate the alarm output terminal of HIAL, LoAL, HdAL, and LdAL. 0 shows no output. 1,2,3 or 4 indicates alarm outputted to AL1, AL2, AU1 or AU2. For example, $AOP = \frac{3}{LoAL} \frac{3}{HdAL} \frac{0}{LoAL} \frac{1}{HIAL}$ It shows that HIAL is sent to AL1, LoAL has no output, HdAL and LdAL are sent to AU1. Note 1: When AUX is used as auxiliary output in bidirectional (heating/refrigerating) control, alarm to AU1 and Au2 won't work. Note 2: Installing L5 dual relay output module in ALM or AUX can implement AL2 or AU2 alarm.	0~4444
<b>Ctrl</b>	Control mode	onoF: on-off control. For situation not requiring high precision; APId: advanced artificial intelligence PID control. Recommended nPid: standard PID algorithm with anti-integral-saturation function (no integral when PV-SV > proportional band); POP: output PV. The instrument works as a temperature retransmitter. SOP: output SV. The instrument works as a set current output.	onoF APId nPid POP SOP
<b>Act</b>	Acting method	rE: Reverse acting. Increase in measured variable causes an decrease in the output, such as heating control. dr: Direct acting. Increase in measured variable causes an increase in the output, such as refrigerating control. rEbA: Reverse acting with low limit alarm and deviation low alarm blocking at the beginning of power on. drbA: Direct acting with high limit alarm and deviation high alarm blocking at the beginning of power on.	rE dr rEbA drbA
<b>A-M</b>	Auto/Manual Control Mode Selection	MAn: Manual control mode. Manually adjust output value of OUP. Auto: Auto control mode. The instrument calculate and control the output value. FMAn: Fixed in manual control mode. Forbidden to switch to auto mode by pressing A/M ( $\leftarrow$ ) key in basic display status. FAut: Fixed in auto control mode. Forbidden to switch to manual mode by pressing A/M key in basic display status.	MAn Auto FMAn FAut
<b>At</b>	auto tuning	oFF: Auto tuning function is disable on: Active auto turning function to calculate the values of parameters P, I, d and Ctl. After auto tuning is accomplished, "At" will be automatically changed to oFF. FoFF: Auto tuning is disabled, and activating auto tuning from basic display status is forbidden.	
<b>P</b>	Proportional band	Proportional band in PID and APID control. Instead of percentage of the measurement range, the unit is the same as PV.	10~9999

		Generally, optimal P, I, D and Ctl can be obtained by auto tuning. They can also be manually input if you already know the correct values.	units																																																				
<b>I</b>	Time Integral of	No integral effect when I=0	0~9999 seconds																																																				
<b>d</b>	Time Derivative of	No derivative effect when d=0	0~999.9 seconds																																																				
<b>Ctl</b>	Control period	Small value improves control accuracy. For SSR, thyristor or linear current output, generally 0.5 to 3 seconds. For Relay output or in a heating/refrigerating dual output control system, generally 15 to 40 seconds, because small value will cause the frequent on-off action of mechanical switch or frequent heating/refrigerating switch, and shorten its service life. Ctl is recommended to be 1/4 – 1/10 of derivative time. (It should be integer times of 0.5 second.) When output type is set to relay (OPt or Aut is set to rELY), Ctl will be limited to more than 3 seconds. Auto tuning will automatically set Ctl to suitable value considering both control precision and mechanical switch longevity.	0.5~120.0 seconds																																																				
<b>CHYS</b>	Control Hysteresis	CHYS is used for on-off control to avoid frequent on-off action of relay. For a reverse acting (heating) system, when PV > SV, output turns off; when PV<SV-CHYS, output turns on. For a direct acting (refrigerating) system, when PV<SV, output turns off; when PV>SV+CHYS, output turns on.	0~2000 units																																																				
<b>InP</b>	Input specification Code	<table border="1"> <thead> <tr> <th>InP</th> <th>Input spec.</th> <th>InP</th> <th>Input spec.</th> </tr> </thead> <tbody> <tr> <td>0</td> <td>K</td> <td>26</td> <td>0~80ohm resistor input</td> </tr> <tr> <td>1</td> <td>S</td> <td>27</td> <td>0~400ohm resistor input</td> </tr> <tr> <td>2</td> <td>R</td> <td>28</td> <td>0~20mV voltage input</td> </tr> <tr> <td>3</td> <td>Spare</td> <td>29</td> <td>0~100mV voltage input</td> </tr> <tr> <td>4</td> <td>E</td> <td>30</td> <td>0~60mV voltage input</td> </tr> <tr> <td>5</td> <td>J</td> <td>31</td> <td>0~500mV voltage input</td> </tr> <tr> <td>7</td> <td>N</td> <td>32</td> <td>100~500mV voltage input</td> </tr> <tr> <td>10</td> <td>extended input specification</td> <td>33</td> <td>1~5V voltage input</td> </tr> <tr> <td>15</td> <td>4~20mA (installed I4 in MIO)</td> <td>34</td> <td>0~5V voltage input</td> </tr> <tr> <td>16</td> <td>0~20mA (installed I4 in MIO)</td> <td>35</td> <td>0~10V</td> </tr> <tr> <td>20</td> <td>Cu50</td> <td>36</td> <td>2~10V</td> </tr> <tr> <td>21</td> <td>Pt100</td> <td>37</td> <td>0~20V</td> </tr> </tbody> </table> <p>Note 1: If specified when ordering, an additional input specification, for example, WRe32, WRe526, WRe520, JPt100 (BA2), G(Cu53), F2, or Square root of 0~5V or 1~5V, can be provided by setting InP=10. Note 2: Input specification can be preset in factory upon request.</p>	InP	Input spec.	InP	Input spec.	0	K	26	0~80ohm resistor input	1	S	27	0~400ohm resistor input	2	R	28	0~20mV voltage input	3	Spare	29	0~100mV voltage input	4	E	30	0~60mV voltage input	5	J	31	0~500mV voltage input	7	N	32	100~500mV voltage input	10	extended input specification	33	1~5V voltage input	15	4~20mA (installed I4 in MIO)	34	0~5V voltage input	16	0~20mA (installed I4 in MIO)	35	0~10V	20	Cu50	36	2~10V	21	Pt100	37	0~20V	0~37
InP	Input spec.	InP	Input spec.																																																				
0	K	26	0~80ohm resistor input																																																				
1	S	27	0~400ohm resistor input																																																				
2	R	28	0~20mV voltage input																																																				
3	Spare	29	0~100mV voltage input																																																				
4	E	30	0~60mV voltage input																																																				
5	J	31	0~500mV voltage input																																																				
7	N	32	100~500mV voltage input																																																				
10	extended input specification	33	1~5V voltage input																																																				
15	4~20mA (installed I4 in MIO)	34	0~5V voltage input																																																				
16	0~20mA (installed I4 in MIO)	35	0~10V																																																				
20	Cu50	36	2~10V																																																				
21	Pt100	37	0~20V																																																				
<b>dPt</b>	Radix point position	Four formats (0, 0.0, 0.00, 0.000) are selectable Note 1: For thermocouples or RTD input, only 0 or 0.0 is selectable, and the internal resolution is 0.1. When S or R thermocouple is used, dPt is recommended to be 0.	0, 0.0, 0.00, 0.000																																																				
<b>ScL</b>	Signal scale low limit	Define scale low limit of input. It is also the low limit of transmitter output (Ctrl=POP or SOP) and light bar display.	-9990~+30000 units																																																				
<b>ScH</b>	Signal scale high limit	Define scale high limit of input. It is also the high limit of retransmission output (Ctrl=POP or SOP) and light bar display.																																																					
<b>Scb</b>	Input Shift Adjustment	Scb is used to shift input to compensate the error caused by transducer, input signal, or auto cold junction compensation of thermocouple. PV_after_compensation=PV_before_compensation + Scb	-1999~+4000 units																																																				
<b>FILt</b>	PV input filter	The value of FILt will determine the ability of filtering noise. When a large value is set, the measurement input is stabilized but the response speed is slow. Generally, it can be set to 1 to 3. If great interference exists, then you can increase parameter "FILt" gradually to make momentary fluctuation of measured value less than 2 to 5. When the instrument is being metrological verified, "FILt" s can be set to 0 or 1 to shorten the response time.	0~40																																																				
<b>Fru</b>	Selection of power frequency and temperature scale	50C: 50Hz, °C. Input has maximum anti-interference ability to 50Hz frequency; 50F: 50Hz, °F. Input has maximum anti-interference ability to 50Hz frequency; 60C: 60Hz, °C. Input has maximum anti-interference ability to 60Hz frequency; 60F: 60Hz, °F. Input has maximum anti-interference ability to 60Hz frequency;	50C, 50F, 60C, 60F																																																				
<b>OPt</b>	main output type	SSr: to output SSr driver voltage or thyristor zero crossing trigger signal. G, K1 or K3 module should be installed. The output power can be adjusted by the on-off time	SSr rELY																																																				

		<p>proportion. The period (Ctl) is generally 0.5~4 seconds.</p> <p>rELy: for relay contact output or for execution system with mechanical contact switch. To protect the mechanical switch, the output period (Ctl) is limited to 3~120 seconds, and generally is 1/5 to 1/10 of derivative time.</p> <p>0-20: 0~20mA linear current output. X3 or X5 module should be installed in OUPt slot.</p> <p>4-20: 4~20mA linear current output. X3 or X5 module should be installed in OUPt slot.</p> <p>PHA: single-phase phase-shift output. K5 module should be installed in OUPt slot. PHA is only for 50Hz power supply, and don't support bidirectional control system.</p>	<p>0-20</p> <p>4-20</p> <p>PHA</p>
<b>Aut</b>	Auxiliary output type	<p>Define Aut only when AUX is worked as the auxiliary output of a heating/refrigerating bidirectional system.</p> <p>SSr: to output SSr driver voltage or thyristor zero crossing trigger signal. G, K1 or K3 module should be installed. The output power can be adjusted by adjusting the on-off time proportion. The period (Ctl) is generally 0.5~4 seconds.</p> <p>rELy: for relay contact output or for execution system with mechanical contact switch. To protect the mechanical switch, the output period (Ctl) is limited to 3~120 seconds, and generally is 1/5 to 1/10 of derivative time.</p> <p>0-20: 0~20mA linear current output. X3 or X5 module should be installed in OUPt slot.</p> <p>4-20: 4~20mA linear current output. X3 or X5 module should be installed in OUPt slot.</p> <p>Note: In a heating/refrigerating bidirectional control system, if any of OPt or Aut is set to rELy, then Ctl is limited to 3~120. For single output control, please set Aut to SSr.</p>	<p>SSr</p> <p>rELy</p> <p>0-20</p> <p>4-20</p>
<b>OPL</b>	Output limit low	<p>0~100%: OPL is the minimum output of OUPt in single directional control system.</p> <p>-1 ~ -120%: the instrument works as a bidirectional system having heating/refrigerating dual output. When Act=rE or rEbA, OUPt (main output) works as heating, and AUX (Auxiliary output) works as refrigerating. When Act=dr or drbA, OUPt works as refrigerating, and AUX works as heating.</p> <p>In a bidirectional system, the heating and refrigerating ability are generally different.</p> <p><math>OPL = -(\text{power when AUX output is maximum} / \text{power when OUPt output is maximum}) \times 100\%</math>.</p> <p>For example, for a heating/refrigerating air condition, its maximum power of refrigerating is 4000W, and maximum power of heating is 5000W, and AUX works as refrigerating, then</p> <p><math>OPL = -(4000/5000) \times 100\% = -80\%</math></p> <p>The range of AUX output can't be freely defined by user. If the internal calculation requires maximum output of AUX (AUX output=OPL), then in 4~20mA output, the AUX output is 20mA. User can't limit the maximum AUX output to 10mA.</p>	<p>-120~</p> <p>+100%</p>
<b>OPH</b>	Output upper limit	<p>OPL limits the maximum of OUPt (main output) when PV&lt;OEF. OPH should be greater than OPL.</p>	<p>0~110%</p>
<b>OPrt</b>	Soft start time	<p>At the beginning of power on, if PV&lt;OEF, it takes OPrt for the output value of OUPt to rise to OPH; if PV&gt;OEF, then the time for output value of OUPt to rise to 100% is not more than 5 seconds. This function is only needed by special requirement.</p> <p>Soft start function doesn't affect the maximum output at auto tuning or manual control. If it is needed to lower the impulse current of induction load, Ctl can be set to 0.5 second, and OPrt 5 seconds.</p>	
<b>OEF</b>	Work range of OPH	<p>When PV&lt;OEF, the upper limit of OUPt is OPL; when PV&gt;OEF, the upper limit of OUPt is 100%.</p> <p>For example, to avoid that the temperature raises too quickly, under 150℃, a heater can work only under 30% of power, then we can set OEF=150.0 (℃), OPH=30 (%)</p>	<p>-9990~</p> <p>+30000 units</p>
<b>Addr</b>	communication address	<p>In the same communication line, different instrument should be set to different address.</p>	<p>0~80</p>
<b>bAud</b>	baud rate	<p>the range of baud rate is 1200~19200bit/s. For D2 dimension instrument, when COMM/AUX slot is used as AUX, bAud should be set to 0.</p>	<p>0~19200</p>
<b>AF</b>	advanced function	<p>AF is used to select advanced function. The value of AF is calculated as below:</p> <p><math>AF = Ax1 + Bx2 + Cx4 + Dx8</math></p> <p>A=0, HdAL and LdAL work as deviation high and low limit alarms; A=1, HdAL and LdAL work as high and low limit alarms, and the instrument can have two groups of high and low limit alarms.</p> <p>B=0, alarm and control hysteresis work as unilateral hysteresis; B=1, as bilateral hysteresis.</p> <p>For instruments with light bar, when C=0, the light bar indicates the output value; when C=1, the light bar indicates the process value.</p> <p>D=0, Loc=808 can access the whole parameter table; D=1, Loc=PASd can access the parameter table.</p> <p>Note: AF=0 is recommended.</p>	<p>0~15</p>

<b>PASd</b>	password	When PASd=0~255 or AF.D=0, setting Loc=808 can enter the whole parameter table. When PASd=256~9999 and AF.D=1, only setting Loc=PASd can access the whole parameter table. Please setting PASd cautiously, if the password is lost, you can't access the parameter table again.	0~9999
<b>SPL</b>	Low limit of SV	Minimum value that SV is allowed to be.	-9990~ +30000 unit
<b>SPH</b>	Upper limit of SV	Maximum value that SV is allowed to be.	
<b>SP1</b>	Setpoint 1	Generally, SV=SP1	SPL~ SPH
<b>SP2</b>	Setpoint 2	when I2 is installed in MIO slot, SP1 and SP2 can be switched by an external switch. If the switch is off, SV=SP1; if the switch is on, SV=SP2.	
<b>EP1~ EP8</b>	Field parameter definition	Define 0~8 of the parameters as field parameters.	nonE and all parameter codes

Note : When indicating temperature, the unit of PV and the parameters is 0.1℃ or 0.1℉ according to parameter Fru. For example, the range of -9990~+30000 means -999.0℃~+3000.0℃ or -999.0℉~+3000.0℉, and the display of number greater than 999.9 will automatically cut the decimal fraction. For the unit of other linear signals, the radix point position is used only for display, and doesn't affect the resolution and range of the internal calculation

### 3.3 Additional Remarks of Special Functions

#### 3.3.1 Single-phase phase-shift trigger output

When OPt is set to PHA, installing a K5 module in OOTP slot can single-phase phase-shift trigger a TRIAC or 2 inverse parallel SCRs. It can continuously adjust heating power by control the conduction angle of thyristor. With non-linear power adjustment according to the characters of sine wave, it can get ideal control. The trigger adopts self-synchronizing technology, so it can also work even when the power supplies of the instrument and the heater are different. Phase-shift trigger has high interference to the electric power, so user should pay attention to the anti-interference ability of other machines in the system. Now the K5 module can be only used in 50Hz power supply.

#### 3.3.2 Alarm blocking at the beginning of power on

Some unnecessary alarms often occur at the beginning of power on. In a heating system, at the beginning of powers on, its temperature is much lower than the setpoint. If low limit and deviation low limit are set and the alarm condition are satisfied, the instrument should alarm, but there is no problem in the system. Contrarily, in an refrigerating system, the unnecessary high limit or deviation high limit alarm may occur at the beginning of power on. Therefore, AI instruments offer the function of alarm blocking at the beginning of power on. When Act is set to rEbA or drbA, the corresponding low or high alarms are blocked until the alarm condition first clears. If the alarm condition is satisfied again, the alarm will work.

#### 3.3.3 Setpoints switch

If an I2 module is installed in MIO slot, a switch can be connected to terminal number 14 and 16 to switch between two different setpoints SP1 and SP2.

#### 3.3.4 Communication function

S or S4 module can be installed at COMM slot to communicate with a computer. The instrument can be controlled by computer. A RS232C/RS485 or USB/RS485 converter can enable a computer connect to AI instruments through RS232 or USB communication port. Every communication port of a computer can connect up to 60 AI instruments, or 80 AI instruments if a repeater is installed. A computer with 2 communication ports can connect to up to 160 instruments. Please note that every instrument connecting to the same communication line should be set to a unique communication address. When number of the instruments is large, two or more computers should be used and built into a local network. AIDCS application software, a distributed control system software developed by Yudian, can control and manage 1~160 AI instruments, record the data, generate and print reports. If users want to develop their own distributed control system by themselves, the communication protocol of AI instruments will be provided free of charge. There are already many famous distributed control system software support AI instruments.

#### 3.3.5 Temperature retransmitter / set current output

Besides AI PID, stand PID control and on-off control, if the output is defined as current output, the instrument can also

---

retransmit PV (process value) or SV (setpoint) into linear current and output from OUP. The precision of current output is 0.2%FS. The corresponding parameters are set as below:

When Ctrl=POP, PV is retransmitted to linear current, the instrument works as temperature retransmitter. When Ctrl=SOP, SV is transmitted and output. The instrument works as a set current output.

OPt defines output type, generally 4~20mA or 0~20mA.

Parameters InP, ScL, ScH, and Scb are used for selecting input specification, setting low limit or high limit of PV and adjusting input.

For example, in order to retransmit temperature read from K thermocouple, range 0~400°C, to current 4~20mA, the parameters are set as below: Ctrl=POP, InP=0, ScL=0.0, ScH=400.0, OPt=4-20, and X3 or X5 linear current module is installed in OUP slot. When the temperature is less than or equal to 0°C, the output is 4mA. When the temperature equals to 400°C, the output is 20mA. The upper limit of transmitter output can be high up to 110% of the range, which means when PV is 0~440°C, output current is 4~21.6mA.